



CUTTER & SUCTION DREDGERS





BELL® CUTTER DREDGER 250-M	4
<ul style="list-style-type: none"> • Intro • General data • Multifunctional at 9 & 15 meters deep 	
BELL® MULTIFUNCTIONAL	8
<ul style="list-style-type: none"> • Bell cutter head • Bell double cutter head • Bell sand production head 	
BELL® ADVANTAGES BCD 250-M	9
<hr/>	
BELL® A-FRAME DREDGER	10
<ul style="list-style-type: none"> • Intro • General data • Main dimensions 	
BELL® HEADS	13
<ul style="list-style-type: none"> • Bell double cutter head • Bell sand production head 	
BELL® ADVANTAGES A-FRAME	13
<hr/>	
BELL® CUTTER DREDGER 300/400	14
<ul style="list-style-type: none"> • Intro • General data • Main dimensions 	
BELL® HEADS	17
<ul style="list-style-type: none"> • Bell cutter head • Bell double cutter head • Bell sand production head 	
BELL® ADVANTAGES BCD 300/400	17
<hr/>	
AVAILABLE OPTIONS	18
<ul style="list-style-type: none"> • Bell dredge computer • Bell sounder system • Production instrumentation 	
CONTROL CABIN	19



BELL® CUTTER DREDGER 250-M 6-7

- Intro
- General data
- Multifunctional at 9 & 15 meters deep

BELL® MULTIFUNCTIONAL 8

- Bell cutter head
- Bell double cutter head
- Bell sand production head

BELL® ADVANTAGES 9

- Advantages of the Bell multifunctional dredger

BELL[®] CUTTER DREDGER 250-M





BELL CUTTER DREDGER 250-M

We are proud to introduce the BCD 250-M, an updated design of the Bell Cutter Dredger (BCD) 250.

A Multifunctional dredge with suction and cutting depth up to 9 or up to 15 meters. It's available in two variations: diesel driven or fully electric. It has a total installed power of 405 kW and is able to produce 1250 m³/h of mixture. The BCD 250-M is multifunctional because three of our dredge heads can be installed for all different types of soil. The water jet assisted cutter head for compact layers of sand, and clay. The water jet assisted double cutter head with double cutter power for even harder materials, and the water jet assisted sand production head for loose materials like silt, sand and gravel.



GENERAL DATA

Engine model	Volvo D13
Engine Power	390 kW
Emission class	Stage V / Tier 4f
Displacement	12,8 L
Total weight	41.500 kg
Height	4 m
Length	22 m
Width	4,7 m
Max. dredging depth	9-15 m
Fuel tank	5000 L
Hydraulic tank	1750 L

BELL 250 PUMP

Mixture capacity (max)	1250 m ³ /h
Pump speed max	900 rpm
Max power at shaft	190 kW
Suction bore	250 mm
Discharge piping	250 mm
Spherical passage	130 mm
Weight (hydraulic)	2600 kg
Weight (electric)	3500 kg
Hydraulic pressure	250 bar
Hydraulic flow	475 L/min
Hydraulic cutter flow	30-50 L/min

MULTIFUNCTIONAL AT 9 & 15 METERS DEEP

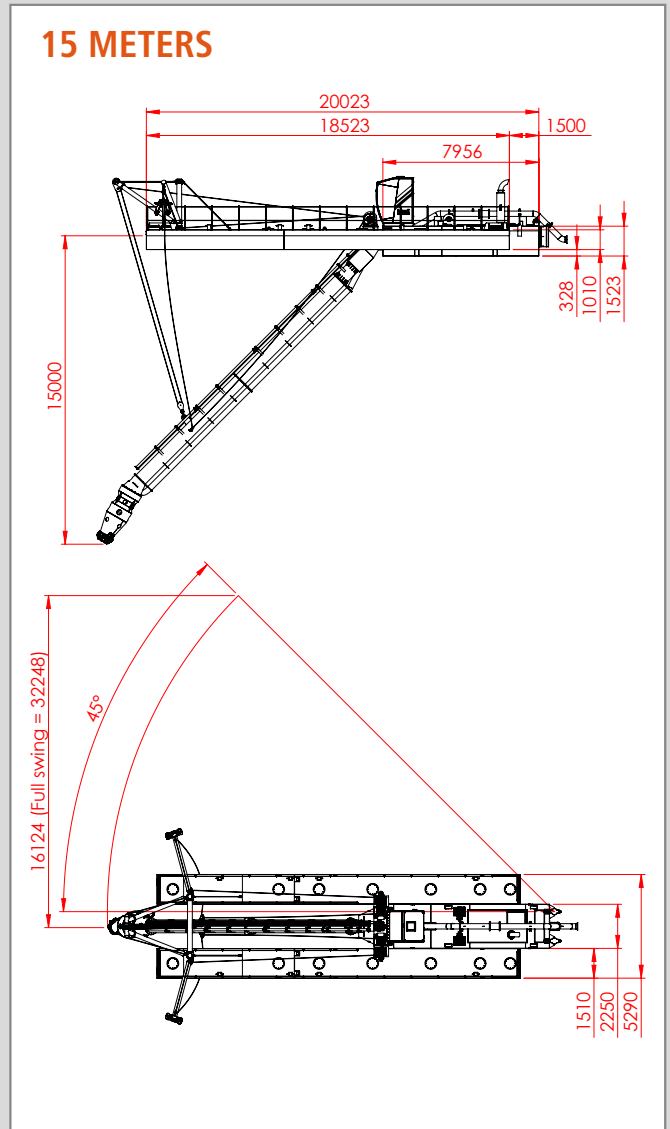
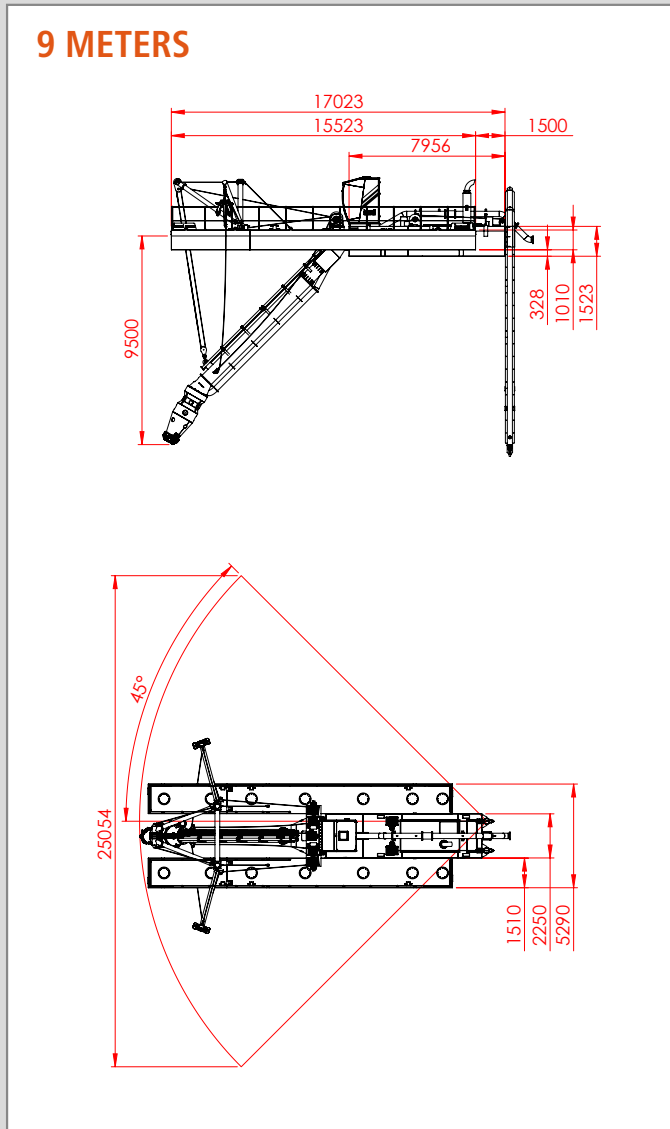

* 4-point mooring is used in 15-meter configuration, see page 9.





BELL CUTTER HEAD

The Bell cutter head, seen in the top left picture below, is a high torque cutter used for agitating compact layers of soil, sand and clays. It is not only able to do this at 9 meters deep like other cutter dredgers from this class, but up to max. 15 meters deep. Besides this it is equipped with water jet nozzles in and around the rotating head to keep it clean and create a better mixture under water.

BELL DOUBLE CUTTER HEAD

The Bell double cutter head, seen in the top right picture below, was originally developed to use free hanging but has proven to be very successful in a fixed set-up too. With double the cutter power and 16 bar on the 11 water jet nozzles in and in between the rotating heads, the hardest soil layers can be dredged.

BELL SAND PRODUCTION HEAD

Maximum production when dredging loose layers of silt, sand and gravel, is ensured by the Bell sand production head. Seen in the bottom left picture below, 8 water jet nozzles around the cage create a high solids mixture under water which is pumped away with maximum efficiency.



ADVANTAGES OF THE BELL MULTIFUNCTIONAL DREDGER

Being able to switch between three different dredge heads is what gave this dredger its multifunctional title. But of course there are more advantages which makes the BCD250-M the best cutter suction dredger in its class.

A few of them are:

- Dredge pump located under water for higher production
- Easily replaceable discharge pipe
(not running through the engine room!)
- Spacious wide-view control cabin
- Up to 15 meters cutting depth

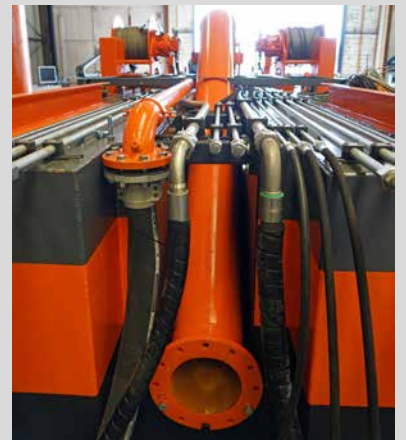



BELL® A-FRAME DREDGER

12-13

- Intro
- General data
- Main dimensions

BELL® HEADS

13

- Bell double cutter head
- Bell sand production head

BELL® ADVANTAGES

13

- Advantages of the Bell A-frame Dredger

BELL® A-FRAME DREDGER



A-FRAME DREDGER



BELL A-FRAME DREDGER

Bell A-frame dredgers are diesel or electric driven floating platforms that maneuver on 4 point mooring.

A Bell pump equipped with either a sand production head for loose soils or double cutter head for compact soils is suspended from an A-frame at the front of the pontoon.

The big advantage of this set-up is that there is virtually no limit to the depth until you can dredge.

With the control cabin placed on top of the engine room, maximum overview is ensured and a large open area on deck makes good access to the pump when doing maintenance.



GENERAL DATA

Engine brand	Volvo
Engine Power	400 kW
Emission class	Stage II/IIIA/ IIIB/IV/V
Displacement	12,8 L
Height	9,2 m
Length	12,5 m
Width	7,8 m
Max. dredging depth	50 m
Fuel tank	5000 L
Hydraulic tank	2000 L
Weight (diesel/hydraulic)	41000 kg
Weight (electric)	44000 kg

BELL 250 PUMP

Mixture capacity (max)	1250 m ³ /h
Solid capacity (max)	375 m ³ /h
Pump speed (max)	900 rpm
Power at shaft (max)	190 kW
Suction bore	250 mm
Discharge piping	250 mm
Spherical passage	130 mm
Hydraulic pressure (max)	250 bar
Voltage	400 Volt

MAIN DIMENSIONS BELL A-FRAME DREDGER 250

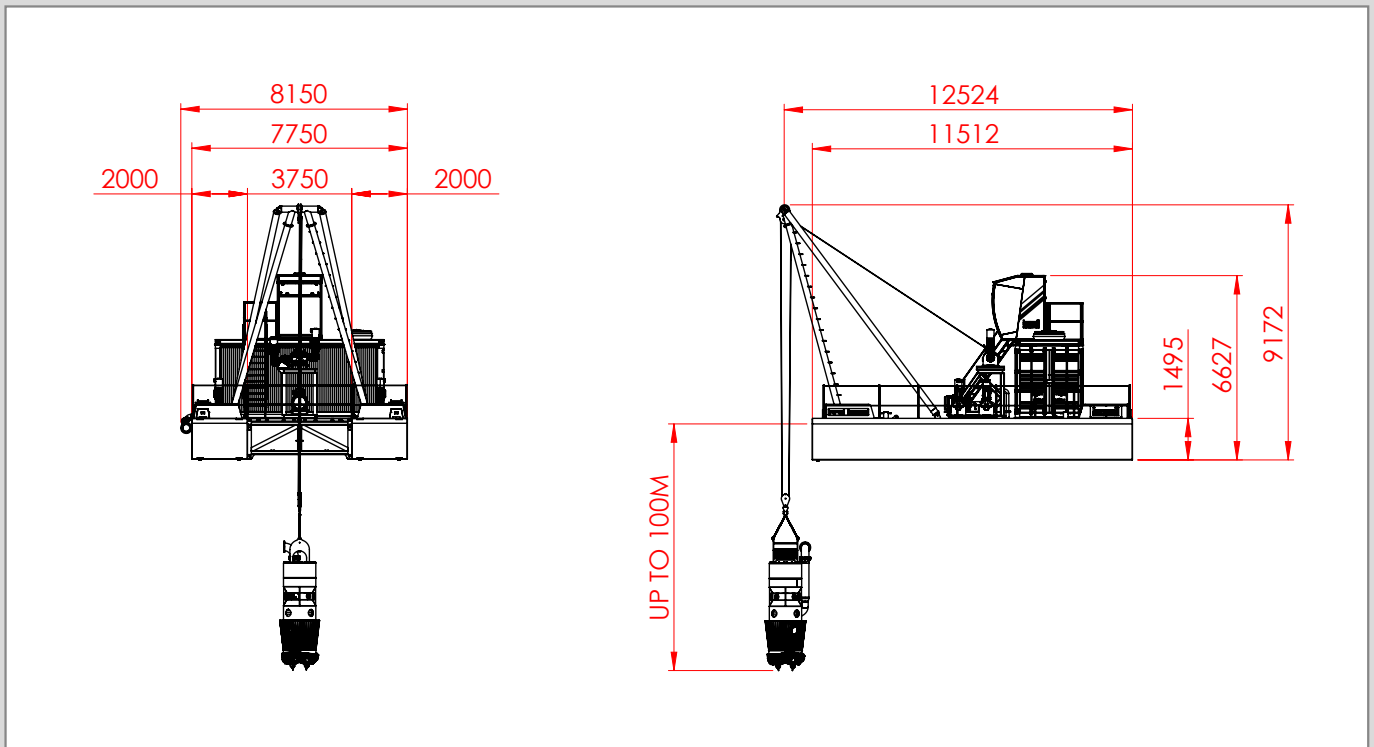

BELL HEADS

BELL DOUBLE CUTTER HEAD

The Bell double cutter head, seen in the top right picture below, was originally developed to use free hanging but has proven to be very successful in a fixed set-up too. With double the cutter power and 16 bar on the 11 water jet nozzles in and in between the rotating heads, the hardest soil layers can be dredged.

BELL SAND PRODUCTION HEAD

Maximum production when dredging loose layers of silt, sand and gravel, is ensured by the Bell sand production head. Seen in the bottom left picture below, 8 water jet nozzles around the cage create a high solids mixture under water which is pumped away with maximum efficiency.

ADVANTAGES OF THE BELL A-FRAME DREDGER

The Bell A-frame Dredger is capable of switching between dredge heads too. Depending on the type of soil, either the sand production head or double cutter head can be attached. But of course there are more advantages which makes the Bell A-Frame the best cutter suction dredger in its class.

A few of them are:

- Diesel driven or fully electric
- Practically no limit to the dredge depth
- Sand head or double cutter head
- Large open area on deck for maintenance
- User friendly control from the cabin





BELL® CUTTER DREDGER 300/400 16-17

- Intro
- General data
- Main dimensions BCD 300/400

BELL® HEADS 17

- Bell cutter head
- Bell double cutter head
- Bell sand production head

BELL® ADVANTAGES 17

- Advantages of the Bell Cutter Dredger 300/400

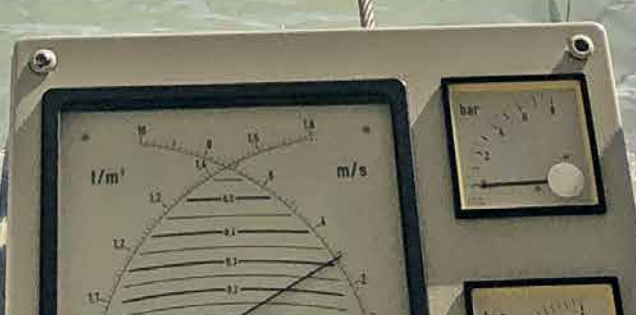

BELL® CUTTER DREDGER 300/400





BELL CUTTER DREDGER 300 & 400

We are proud to introduce the BCD 300 and BCD 400.

These are the most powerful Bell Cutter Dredgers with cutting depths up to 15 meters and dredging depths up to 21 meters. They are available in two variations: diesel driven or fully electric. They are multifunctional because three of our dredge heads can be installed for all different types of soil. The water jet assisted cutter head for compact layers of sand, and clay. The water jet assisted double cutter head with double cutter power for even harder materials, and the water jet assisted sand production head for loose materials like silt, sand and gravel.



GENERAL DATA

300

400

Engine brand	Volvo	Volvo
Power on pump	368 kW	551 kW
Emission class*	Stage V	Stage V
Displacement	12,8 L	16,12 L
Weight (diesel/hydraulic)	120,5 ton	135,5 ton
Max. cutter depth	15 m	15 m
Max. suction depth	21 m	21 m
Fuel tank	2x 11 ton	2x 11 ton
Hydraulic tank	500 L	1000 L
Weight (electric)	130,5 ton	145,5 ton
Cutter power (standard)	55 kW	110 kW
Cutter power (heavy duty)	110 kW	180 kW

BELL PUMP

300

400

Mixture capacity (max)	1800 m ³ /h	3150 m ³ /h
Solid capacity (max)	540 m ³ /h	945 m ³ /h
Pump speed (max)	750 rpm	600 rpm
Power at shaft (max)	300 kW	500 kW
Suction bore	Ø300 mm	Ø400 mm
Discharge piping	Ø300 mm	Ø400 mm
Spherical passage	155 mm	210 mm
Hydraulic pressure (max)	300 bar	300 bar
Voltage	1000 V	1000 V

* Other emission classes on request

MAIN DIMENSIONS BCD 300-400

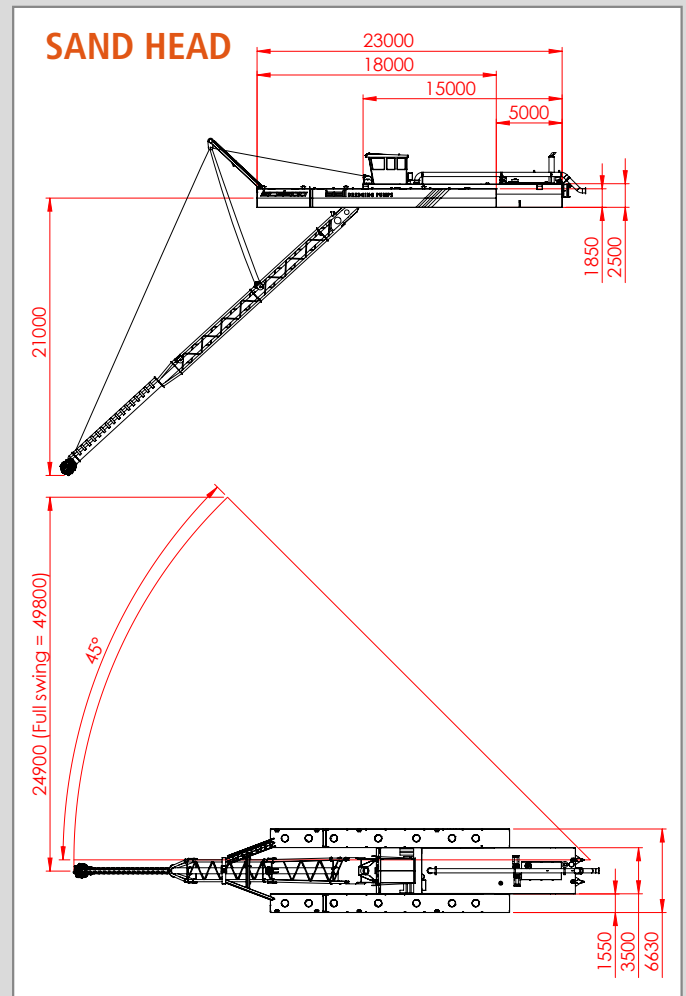
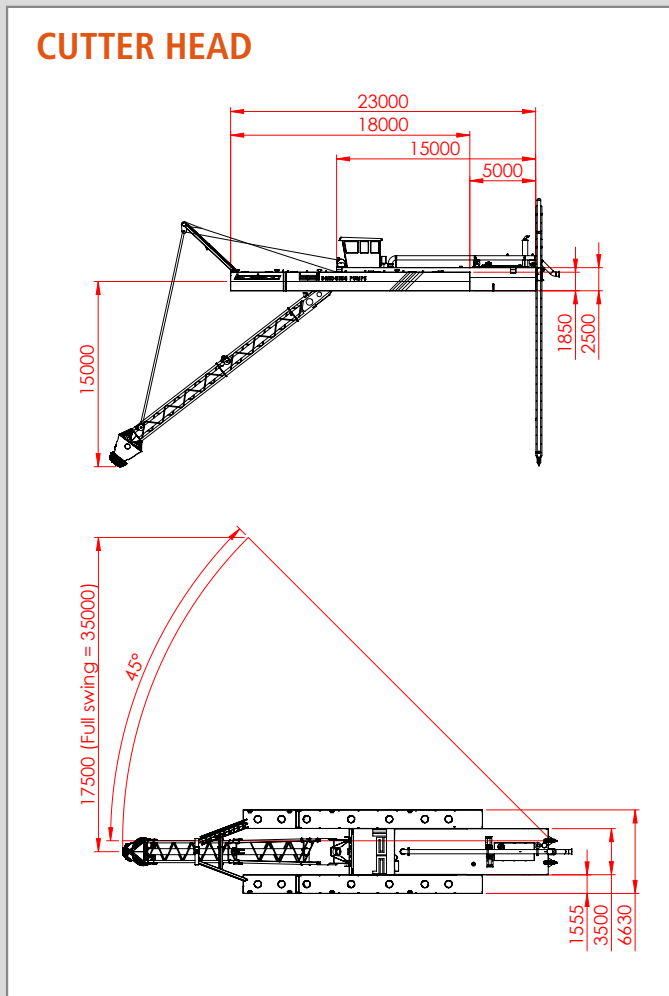

APPLICABLE BELL HEADS

- **BELL CUTTER HEAD**
(up to 15 meters)
- **BELL DOUBLE CUTTER HEAD**
(up to 15 meters)
- **BELL SAND PRODUCTION HEAD**
(up to 21 meters)



The Bell cutter head

ADVANTAGES OF THE BELL CUTTER DREDGER 300-400

Being able to switch between three different dredge heads is what gave these dredgers their multifunctional title. But of course there are more advantages which makes them the best cutter suction dredgers in their class.

A few of them are:

- Spacious wide-view control cabin
- High cutter power
- Up to 15 meters cutting depth
- Large volume high pressure water jet
- Up to 21 meters dredging depth

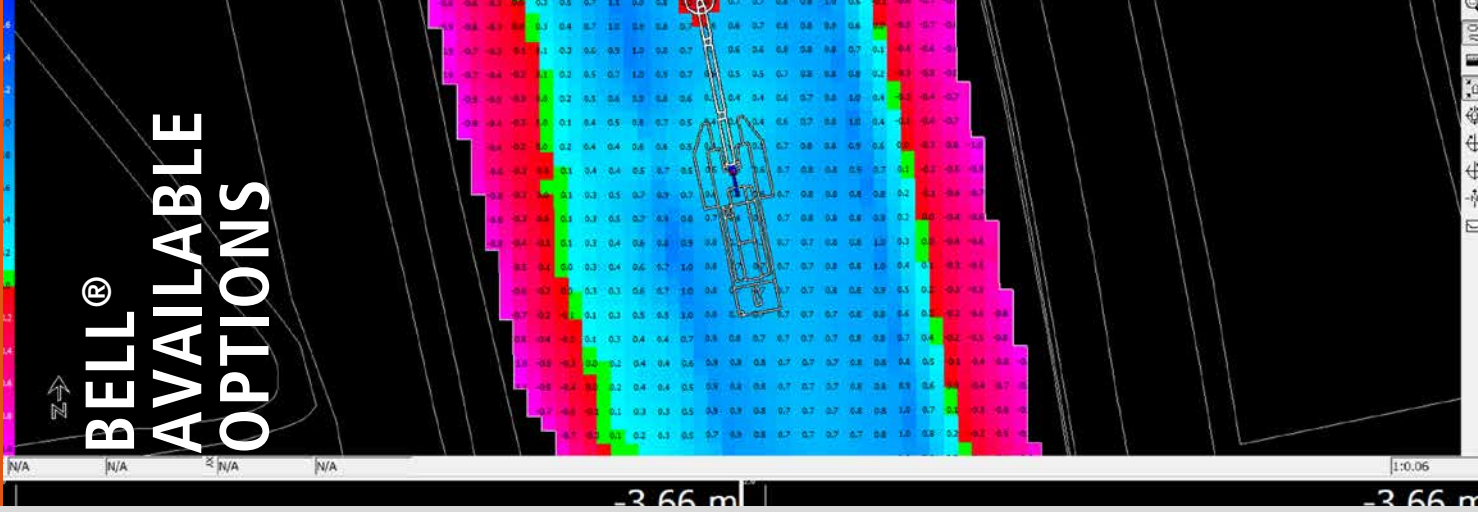

BELL® DREDGE COMPUTER

SPECIFICATIONS

- Industrial Intel Computer
- Internal (G)PS/GLONASS (RTK) receiver
- Industrial GSM/GPRS/UMTS Modem
- Wide range of accessories and sensors
- Dimensions: 40 x 23 x 11 cm

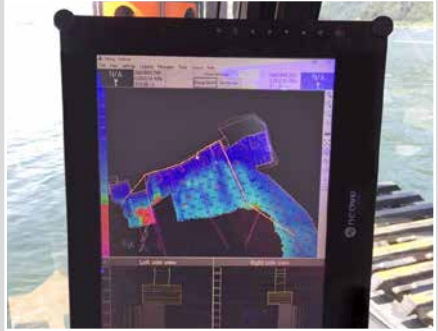

BELL® SOUNDER SYSTEM

BELLsounder is designed to be a simple and rugged hydrographical survey solution with the basic functions of an echo sounder. Depending on the connected sensors, BELLsounder will function as a dual or a single frequency echo sounder. Powered by either an internal Trimble or a Hemisphere GNSS receiver, it provides the perfect solution for a hydrographic survey solution. The BELLsounder consists of a rugged Peli Case that provides a protected housing for every environment.

PRODUCTION INSTRUMENTATION

Flow measurement together with non-nuclear density measurement calculate very accurately the exact production of solid material of the Bell dredgers. Suitable for salt water and fresh water, in every kind of dredging or mining application and accurate with all densities and grain sizes.





CONTROL CABIN

BCD 250-M



A climate controlled, spacious cabin with comfortable chair and windows 180 degrees from left to right ensures maximum operator comfort. The dredger is controlled with two joysticks and all aspects of the dredging process, described on page 6, are monitored on two tablet screens. A rear view camera is installed on the backside of the cabin.

A-FRAME



CUTTER DREDGER 300/400





member of **DIESEKO GROUP**

MORE INFORMATION:

BELLDREDGING.COM

Bell Dredging Pumps B.V. | Winkelerzand 1a | 1731 LR Winkel, the Netherlands | Telephone: +31(0)224-855 340
www.BellDredging.com | info@BellDredging.com | VAT: NL8522.96.964 | COC: 56 77 52 45

092021-EN

Dealer:



bell
DREDGING EQUIPMENT