

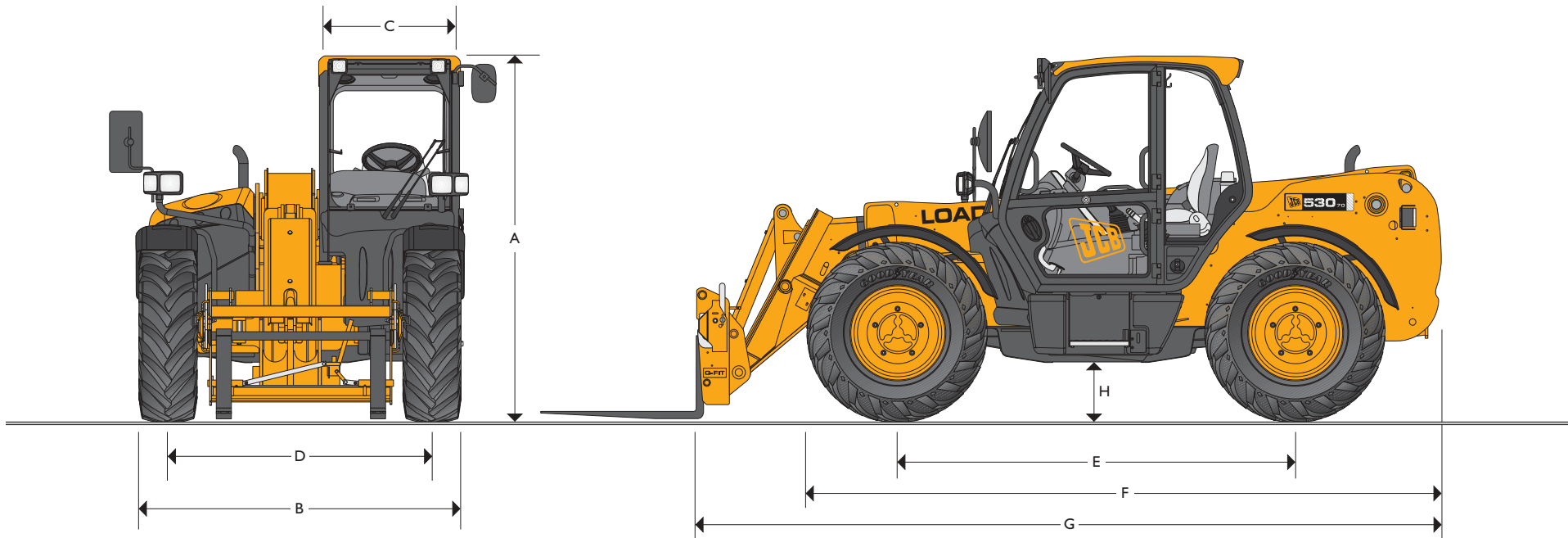

JCB LOADALL | 530-70



MAX. PAYLOAD: 3 tonnes (6614lb)
MAX. LIFT HEIGHT: 7 metres (23ft)
MAX. HORSEPOWER: 74.6 kW (100hp)



STATIC DIMENSIONS

Machine model	530-70
	m (ft-in)
A Overall height	2.49 (8-2)
B Overall width (over tyres)	2.23 (7-4)
C Inside width of cab	0.94 (3-1)
D Front track	1.81 (5-11)
E Wheelbase	2.75 (9-0)
F Overall length to front tyres	4.38 (14-4)

Machine model	530-70
	m (ft-in)
G Overall length to front carriage	4.99 (16-4)
H Ground clearance	0.40 (1-4)
Outside turn radius (over tyres)	3.7 (12-2)
Departure Angle	Degrees 43
Weight	kg (lb) 6800 (14990)
Tyres	15.5/80-24



LIFT PERFORMANCE

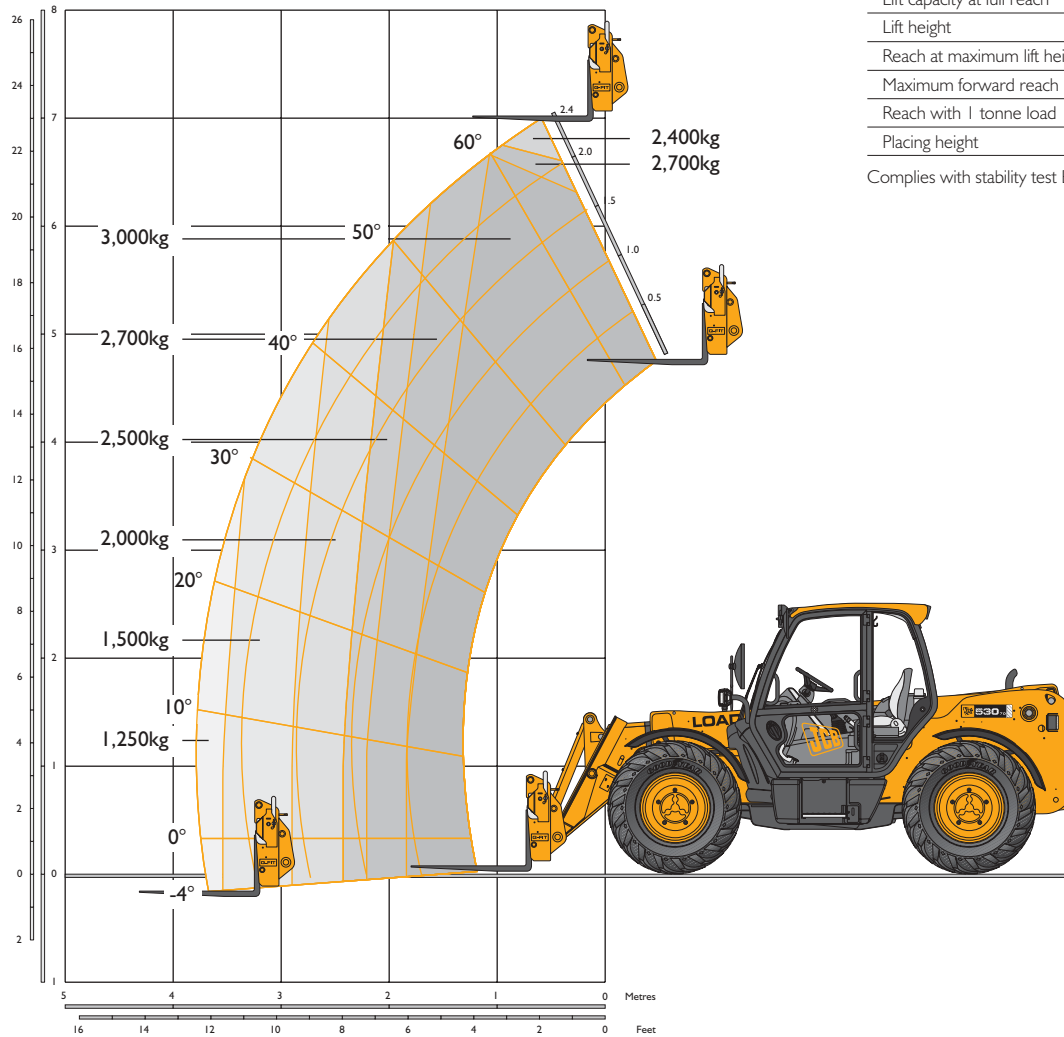

LIFT PERFORMANCE

Machine Model	530-70	
Maximum lift capacity	kg (lb)	3000 (6614)
Lift capacity to full height	kg (lb)	2400 (5291)
Lift capacity at full reach	kg (lb)	1250 (2756)
Lift height	m (ft-in)	7.0 (23-0)
Reach at maximum lift height	m (ft-in)	0.48 (1-7)
Maximum forward reach	m (ft-in)	3.7 (12-2)
Reach with 1 tonne load	m (ft-in)	3.7 (12-2)
Placing height	m (ft-in)	6.3 (20-8)

Complies with stability test EN 1459 Annex B.



ENGINE

4 cylinders. Bore 103mm (4.06in); stroke 127mm (5in); displacement 4.20ltr (256 in³).

Latest technology and advanced design provides low fuel consumption, reduced noise, high torque and power output, total reliability and minimal maintenance.

Easily replaceable pre-finished dry liners, five bearing, heat treated crankshaft. Expansion controlled pistons. Two-stage, dry type air filter with primary and safety elements.

Engine conforms with EC mobile off-highway emissions regulations (stage I).

Engine options: Power at 2200 rpm – 59.7kW (80hp) naturally aspirated – Torque at 1400 rpm 290 Nm (213.8 lbf/ft).
Power at 2200 rpm – 74.6kW (100hp) turbo charged – Torque at 1400 rpm 402 Nm (296 lbf/ft).

TRANSMISSION

JCB 4 speed powershift transmission incorporating torque converter, bevel box and a 4 speed powershift gearbox in one resiliently mounted unit.

A combined steering column mounted switch incorporating directional control and 4 forward and reverse powershift gears. Travel speed 28km/h (17mph). (32km/h (20mph) travel speed when 2/4 WD select is ordered).

Front and rear drive axles

JCB epicyclic hub reduction drive/steer axles with Max-Trac torque proportioning differentials. Permanent 4 wheel drive.

BRAKES

Service brakes - Hydraulically activated, self-adjusting, oil-immersed in-board multi-disc type in front axle.

Parking brake - Hand operated disc brake on output of gearbox.

BOOM AND CARRIAGE

Boom is manufactured from high tensile steel.

Low maintenance, hard wearing pads.

JCB Q-fit self-levelling carriage with lever operated pin locking accepts pallet forks and a wide range of attachments.

One boom end auxiliary hydraulic service fitted as standard.

SAFETY CHECK VALVES

Fitted to carriage tilt, telescopic and boom lift rams.

Chassis levelling (sway) ram model fitted with check valves on rod and head side plus cut out system to disconnect movement when boom is raised.

SERVICE CAPACITIES

	litres (UK gal)
Fuel tank	125 (27.5)
Hydraulic tank	113 (24.8)
Coolant	23 (5.1)

HYDRAULICS

Two (three stage for turbo) stage gear pump with suction strainer and filter.

Operating system pressure	241
Main Hydraulics	82
Steering System (Turbo Only)	(44)
Cooling System	37
Total Flow	119 (163)
Hydraulic Cycle Times	Seconds
Boom raise	7.2
Boom lower	5.4
Extend	6.8
Retract	5.0
Bucket dump	3.5
Bucket crowd	2.9

ELECTRICS

12 v negative earth. 92 AH battery. 65 amp alternator. Full road lighting. Reversing light. Direction indicators. Hazard warning. Reverse alarm.

CAB

Quiet safe and comfortable cab conforms to ROPS ISO 3471 and FOPS ISO 3449. Tinted glass all round. Laminated roof screen. Roof bars, front, rear and roof screen wash/wipe and heater/screen demister. Opening rear window. Audio-visual warning system for coolant temperature, engine oil pressure, air cleaner, battery charge, transmission oil temperature and pressure. Hourmeter and road speed indicator. Engine temperature, fuel gauge and inclinometer.

Mechanical joystick, direct acting hydraulic control levers. Adjustable steer column with stalk bar powershift change and forward reverse shuttle. Throttle and brake pedal. Adjustable deluxe seat with adjacent park brake fitted.

Automatic eye level audio-visual load moment indicator warning system receiving a signal from a load sensor on the rear axle.

This system continuously monitors the machine's forward stability and leaves the operator in control at all times.

Safety canopy as above but with side glass and roof glass only (screen wiper and heater/screen demister not applicable).

STEERING

Hydrostatic power steering with power track rods on both axles.

Three steer mode options: front wheel steer; all wheel steer; crab steer: operated from in the cab by a selection switch, or with automatic alignment.

OPTIONS AND ACCESSORIES

Options: Front and rear working lights, rotating flashing beacon, fire extinguisher, radial industrial tyres, electrical 2/4WD select, limited slip differential in front axle, windscreen guard, deluxe suspension seat, air suspension seat, deluxe cab trim, roof and front screen blind, radio kit, heavy duty battery, air conditioning.

1 lever mechanical joystick, with push button extend and retract.

Attachments: Contact your local dealer for details of the comprehensive range.



A GLOBAL COMMITMENT TO QUALITY

JCB's total commitment to its products and customers has helped it grow from a one-man business into Britain's largest privately owned manufacturer of backhoe loaders, crawler excavators, wheeled excavators, telescopic handlers, wheeled loaders, dump trucks, rough terrain fork lifts, industrial fork lifts, mini/midi excavators, skid steer loaders and tractors.

By making constant and massive investments in the latest production technology, the JCB factories have become some of the most advanced in Europe.

By leading the field in innovative research and design, extensive testing and stringent quality control, JCB machines have become renowned all over the world for performance, value and reliability.

And with a global sales and service network of over 400 distributors and agents, the company exports over 70% of its production to all five continents.

Through setting the standards by which others are judged, JCB has become one of Britain's most impressive success stories.

